

1. Description



Stainless Steel Banding Strap is a high-strength, corrosion-resistant fastening solution designed for demanding applications. Manufactured from various grades of stainless steel, this banding provides durable and long-lasting securement for bundling, clamping, identifying, and mounting items across diverse industries. It is typically applied using specialized tensioning tools and secured with compatible stainless steel buckles or clips, ensuring a reliable and robust connection in harsh environmental conditions, including outdoor, marine, and industrial settings.

2. Key Features

- **Superior Corrosion Resistance:** Excellent resistance to atmospheric corrosion, chemicals, and saltwater (especially Grades 304 and 316), ensuring longevity in harsh environments.
- **High Tensile Strength:** Provides strong, secure fastening capable of withstanding significant loads and vibrations.
- **Durability:** Resistant to abrasion, impact, and wear, maintaining integrity over time.
- **Wide Temperature Range:** Suitable for applications involving extreme temperatures, both high and low.
- **UV Resistance:** Unaffected by prolonged exposure to sunlight, ideal for outdoor applications.
- **Non-Toxic & Hygienic:** Suitable for applications in food processing or sensitive environments (verify grade suitability).
- **Versatility:** Adaptable for securing cables, hoses, pipes, signs, insulation, and various other components.
- **Professional Finish:** Offers a clean, finished appearance once installed.
- **Safety Edge Option:** Available with deburred or rounded edges for safer handling.

3. Applications

- Securing cables and hoses in industrial and marine environments.
- Mounting traffic signs, signals, and control boxes to poles.
- Fastening insulation materials around pipes and ducts.
- Bundling pipes, conduits, or timber.
- General repairs and maintenance in construction, utilities, oil & gas.
- Automotive clamping applications.
- Food and beverage processing equipment assembly (using appropriate grades).

4. Technical Data

- **Material Grades:** Typically available in SS201, SS304, SS316.
 - Note: SS201 offers general-purpose use with good strength. SS304 provides excellent corrosion resistance for general outdoor and industrial use. SS316 offers superior corrosion resistance, especially against chlorides and acids, making it ideal for marine, coastal, and chemical environments.
- **Tensile Strength:** Varies by grade and dimensions. Typically ranges from 500 – 850 MPa (72,500 – 123,000 psi).
- **Yield Strength:** Typically ranges from 200 – 550 MPa (29,000 – 79,800 psi).
- **Elongation at Break:** Typically 40–50%.
- **Available Widths:** Common widths include 1/4" (6.4mm), 3/8" (9.5mm), 1/2" (12.7mm), 5/8" (16.0mm), 3/4" (19.0mm). Other sizes may be available upon request.
- **Available Thicknesses:** Common thicknesses include 0.015" (0.4mm), 0.020" (0.5mm), 0.025" (0.64mm), 0.030" (0.76mm). Thicker bands generally provide higher strength.
- **Standard Coil Length:** Typically 100 ft (30.5m) or 50m rolls. Custom lengths may be available.
- **Edge Finish:** Rounded Safety Edge for manual handling to reduce injury risk.
- **Operating Temperature Range:** Suitable for applications from approximately -60°C to +530°C (-76°F to +986°F). Performance under load at temperature extremes depends on grade and specific conditions.
- **Melting Point:** Approximately 1400–1450°C (2550–2650°F), varying slightly by specific grade.
- **Compliance:** May conform to standards such as ASTM A240/A666 (for base material).

5. Packaging

- Typically supplied in coils. Often packaged in durable plastic dispensers (totes) or cardboard boxes for easy handling and protection.
- Standard coil Quantity: 180 / 240 coils per carton/pallet.

6. Associated Products

- **Stainless Steel Buckles/Clips:** Required for securing the band. Must be compatible grade and size. Such as Ear-lokt Banding Buckles, Sru-lokt Banding Buckles and Wing Seals.
- **Banding Tools:** Manual tensioning and cutting tools specifically designed for stainless steel banding Such as Standard Banding Tool – LYBT001, Heavy Duty Banding Tool – LYBT003.

7. Handling and Storage

Store in a dry place to prevent surface contamination. Handle with gloves, especially if using standard slit edge banding, to avoid cuts.

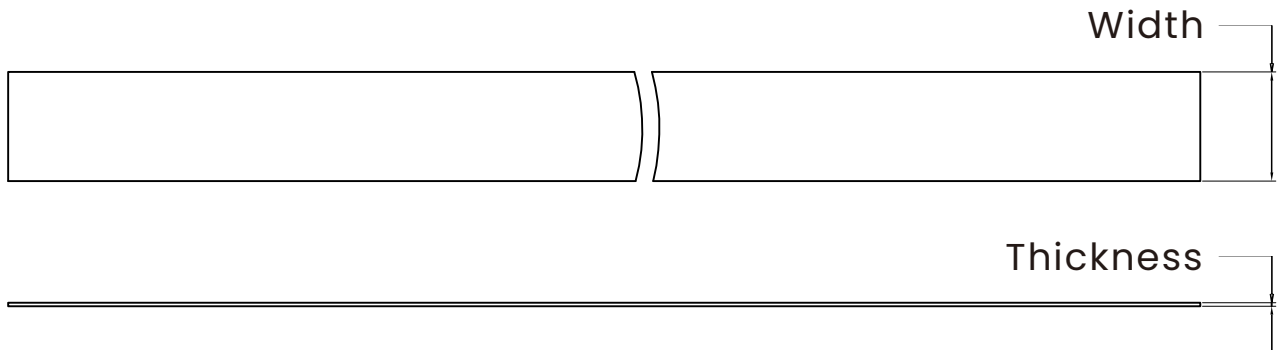
8. Specifications

Light Duty Bands

Width		Thickness		Optional Length(m)	Optional Material
inch	mm	inch	mm		
3/8	9.5	0.015	0.40	30 / 50 / 100	SS304
1/2	12.7	0.015	0.40	30 / 50 / 100	SS304
5/8	16.0	0.015	0.40	30 / 50 / 100	SS304
3/4	19.0	0.015	0.40	30 / 50 / 100	SS304
3/8	9.5	0.020	0.50	30 / 50 / 100	SS304 / 316
1/2	12.7	0.020	0.50	30 / 50 / 100	SS304 / 316
5/8	16.0	0.020	0.50	30 / 50 / 100	SS304 / 316
3/4	19.0	0.020	0.50	30 / 50 / 100	SS304 / 316

Commonly Used Bands

Width		Thickness		Optional Length(m)	Optional Material
inch	mm	inch	mm		
3/8	9.5	0.028	0.70	30 / 50	SS201 / 304
1/2	12.7	0.028	0.70	30 / 50	SS201 / 304
5/8	16.0	0.028	0.70	30 / 50	SS201 / 304
3/4	19.0	0.028	0.70	30 / 50	SS201 / 304
1/2	12.7	0.030	0.76	30 / 50	SS201 / 304
5/8	16.0	0.030	0.76	30 / 50	SS201 / 304
3/4	19.0	0.030	0.76	30 / 50	SS201 / 304

Heavy Duty Bands

Width		Thickness		Optional Length(m)	Optional Material
inch	mm	inch	mm		
1/2	12.7	0.040	1.0	30	SS201 / 304
5/8	16.0	0.040	1.0	30	SS201 / 304
3/4	19.0	0.040	1.0	30	SS201 / 304
1	25.4	0.040	1.0	30	SS201 / 304
1-1/4	32.0	0.040	1.0	30	SS201 / 304

Disclaimer: The information provided in this datasheet is typical for the product category and should be used as a guide. Values may vary depending on the specific grade, dimensions, and manufacturing process. Users should verify the suitability of the product for their specific application and refer to specific batch test certificates if required. Bandtite assumes no liability for the use or misuse of this information.